

## Pouch Dryer

FOR POUCHES AND FLEXIBLE PACKAGING OF ALL SIZES

PERFECT FOR



FEATURES AND BENEFITS

- Dry all surfaces of packaging
- Available in single or multi-lane formats
- Dedicated gusset drying
- Open mesh conveyor for maximum airflow
- Hold-down belt keeps product secure
- Very low maintenance

IDEAL FOR FLEXIBLE PACKAGING

- Lay flat pouches
- Stand-up pouches
- Doy packs
- Liquid Pouches
- Flat bottom bags
- Ready meal trays

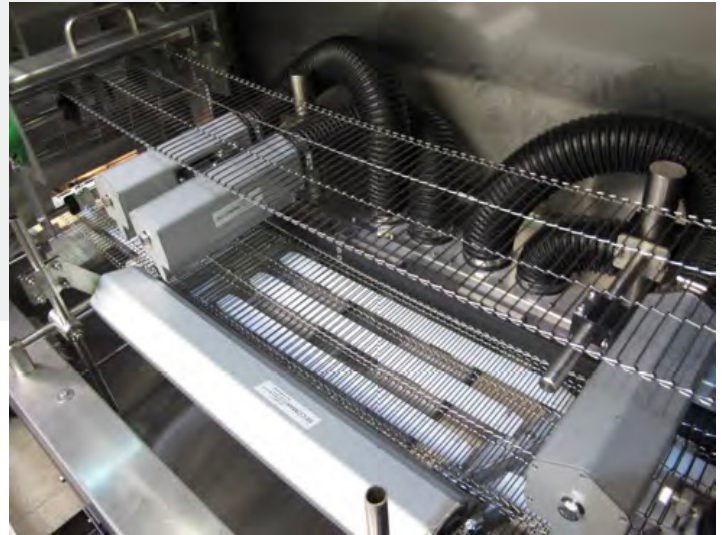

Product supplied may differ from image based on container drying requirements. Image represents the Pouch Dryer (interior).

MTBF	2,208 Hrs
MTTR	2 Hr
Efficiency	99.9
Noise Level*	≤ 85 dB(A)

\*Noise levels have been measured at a distance of 1m from the machine.

DRYING MACHINES



Pouch dryer module (exterior)

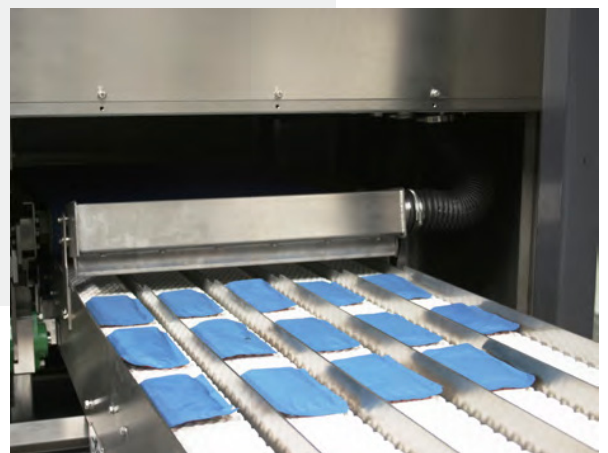

Pouch dryer (multi-lane)

## Pouch Dryer

### DIMENSIONAL DRAWING

	TECHNICAL DATA
Motor	11kW
Voltage	380-415 V / 50 Hz   440-480 V / 60 Hz
Phase	3
Energy Consumption	8kW
Current Protection	32 A (Back Up)
Nominal Current	18 A
Noise level	< 85 dB A

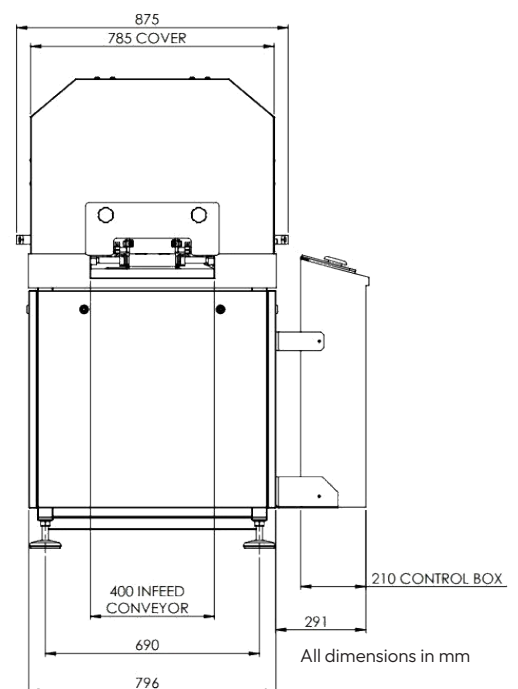
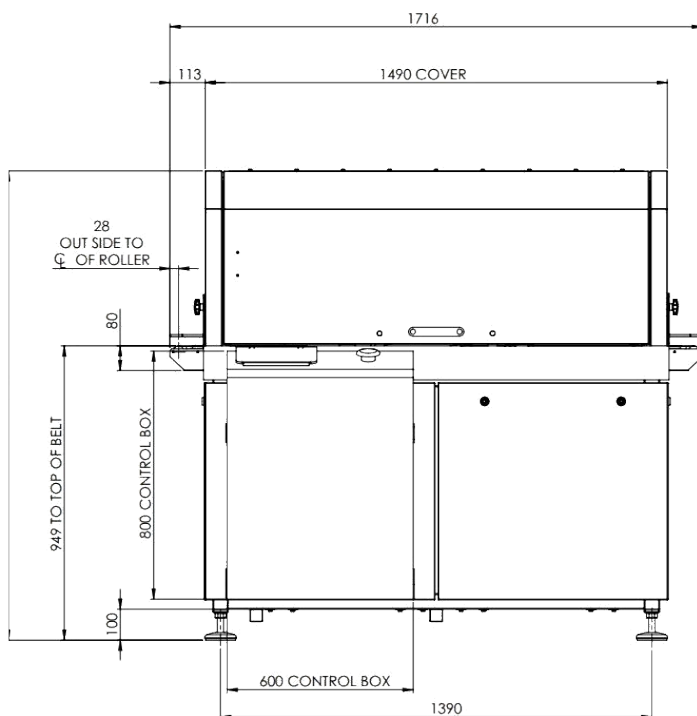
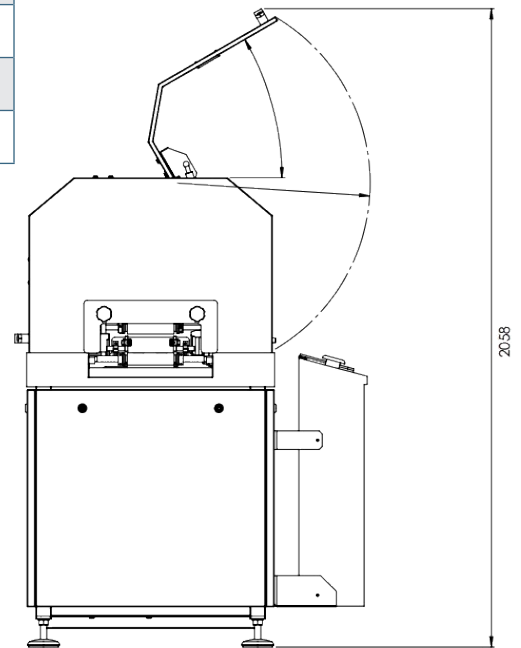

All dimensions in mm

DRYING MACHINES