

Fliegend gelagerte Einschubeinheiten Querstromventilatoren Typenreihe VQE

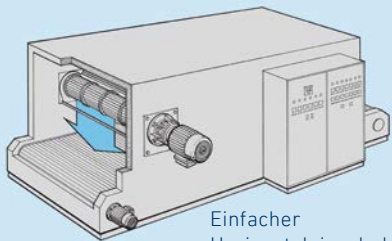

Einfacher
Horizontaleinschub

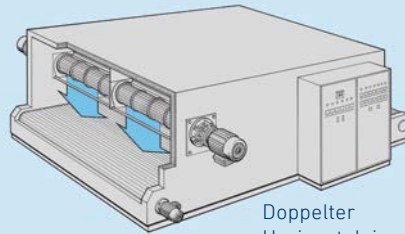

Doppelter
Horizontaleinschub

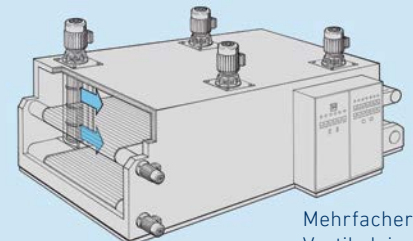

Mehrfacher
Vertikaleinschub

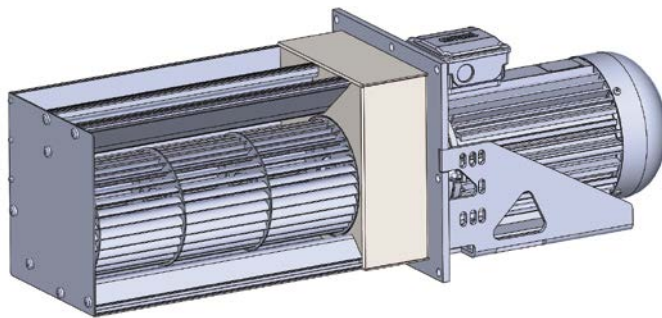

VORTEILE FÜR DIE KONSTRUKTION UND ANWENDUNG

- Verringerter Aufwand für Konstruktion, Produktion und Montage
- Erweiterte Möglichkeiten des Einbaus
- Weniger Anlagenöffnungen
- Einfache Bedienung und Wartung
- Eine Zugangsseite
- Platzsparende Maschinen- und Aufstellung

ANWENDUNGSFÄLLE



Kühlen



Heizen



Trocknen



Rösten



Räuchern



Sortieren



Kontinuierlich



Leise



Hygienisch



Emissions-
reduktion

DER AUFWAND

FÜR KONSTRUKTION, EINBAU,
BEDIENUNG UND WARTUNG
REDUZIERT SICH WESENTLICH.

Overhung slide-in units

Tangential Fans Series VQE

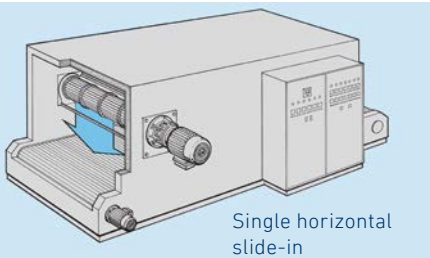

Single horizontal slide-in

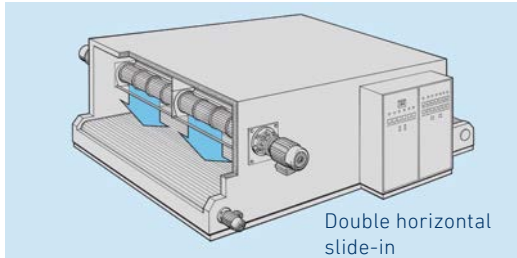

Double horizontal slide-in

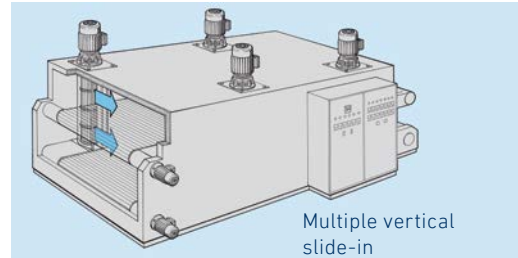

Multiple vertical slide-in

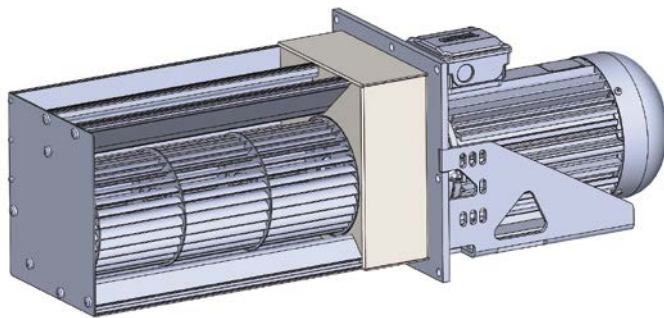

ADVANTAGES FOR ENGINEERING AND APPLICATION

- Reduced time and effort for engineering, production and assembly
- Expanded assembly options
- Reduced number of system openings
- Simple operation and maintenance
- One operator side
- Space-saving machinery and system set-up

APPLICATIONS



TIME AND EFFORT

FOR ENGINEERING, ASSEMBLY,
OPERATION AND MAINTENANCE
IS REDUCED DRAMATICALLY.