

## Mistral X

FEATURING INDIVIDUALLY  
ADJUSTABLE MICRO-NOZZLES

PERFECT FOR



FEATURES AND BENEFITS

- Dry aluminium, glass or PET containers
- Unique & adjustable micro-nozzle design
- Remove moisture from awkward places:
  - Underneath bottle caps
  - Crown caps
  - Screw caps
  - Container seals
  - Bottle necks
  - Jar screw threads
- Quick changes between container size (SMED)
- Compact for simple installation
- Very low maintenance
- Prevent rust, discolouration, bacterial growth and smudged date codes



Product supplied may differ from image based on container drying requirements. Image represents Mistral X Drying Module.

MTBF	19,872 Hrs
MTTR	<1 Hr
Efficiency	99.98
Noise Level*	≤ 83 dB(A)

\*Noise levels have been measured at a distance of 1m from the machine.

DRYING MACHINES

### MISTRAL V CONFIGURATION TOOL

Bottle Application	Area of Drying	Max Conveyor Speed M/Min	Number of Nozzles	Length (mm)
Glass Bottles - Rust Prevention	Under Crown	>60 m/min	48	853
PET Bottles - Prior to Visual Inspection	Cap	<96 m/min	48	810
		<120 m/min	72	1373

## Mistral X

### DIMENSIONAL DRAWING

TECHNICAL DATA	
Air Supply	3/4" BSP Connector
Power Supply	24 V DC / 220-230V
Air Consumption	56 SCFM
Working Pressure	4 Bar

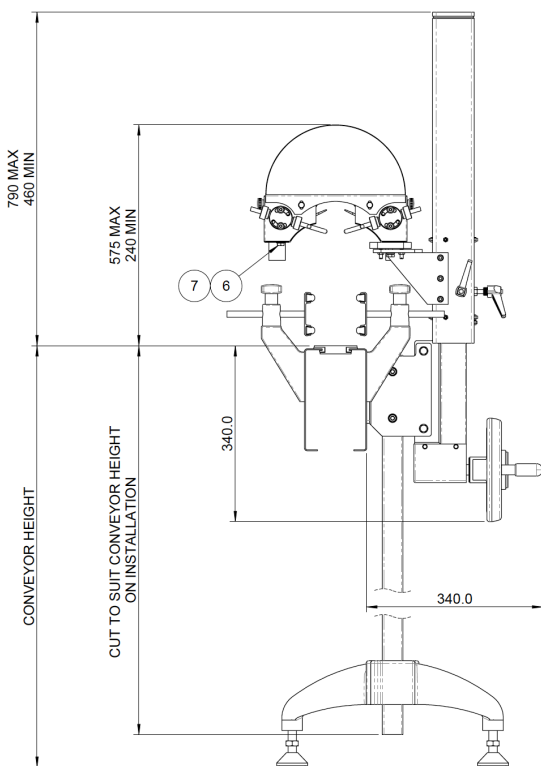
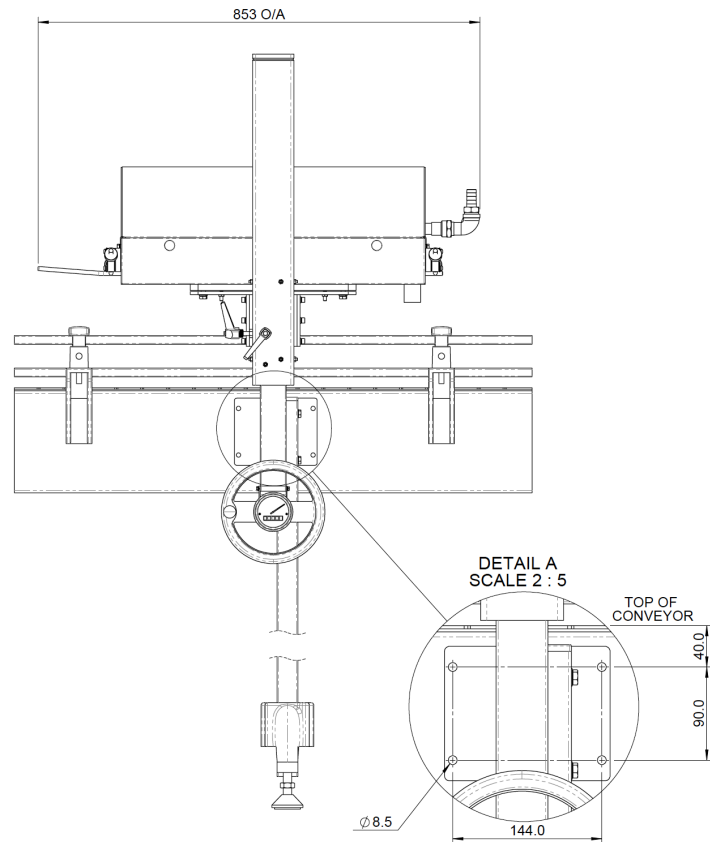
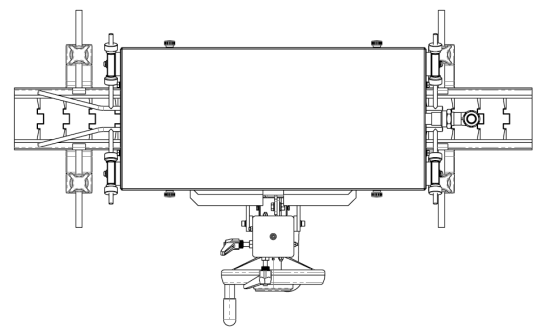

DRYING MACHINES

All dimensions in mm